



Sound 5

Operating Instructions











0065843581

Order no. 6462 2665 76 Part no. 006 584 35 81 Edition C MY 2012 MB



Mercedes-Benz

Symbols

-  Warning
-  Environmental note
-  Possible vehicle damage
-  Tip
-  Action required
-  Continuation symbol
-  Page reference
-  Messages in the display

Registered trademarks

- Windows Media[®] is a registered trademark of the Microsoft Corporation in the USA and other countries.

Vehicle Distributor

In the USA:	In Canada:
Mercedes-Benz USA, LLC One Mercedes Drive Montvale, NJ 07645-0350 www.mbusa.com www.mbsprinterusa.com Customer Assistance Center: 1-877-762-8267	Mercedes-Benz Canada, Inc. 98 Vanderhoof Avenue Toronto, ON M4G 4C9 www.mercedes-benz.ca Customer Relations Department: 1-800-387-0100

Mercedes-Benz USA, LLC and Mercedes-Benz Canada, Inc. are Daimler enterprises.

Canada only:

"Authorized Sprinter Dealer" is defined as an authorized Mercedes-Benz Sprinter Dealer.

Publication details

Internet

Further information about Mercedes-Benz vehicles can be found online at:
www.mercedes-benz.com

Editorial office

Questions or suggestions concerning this Operator's Manual may be directed to the technical documentation team at the address given on the inside of the front cover.

© Mercedes-Benz USA, LLC

© Mercedes-Benz Canada, Inc.

Mercedes-Benz USA, LLC and Mercedes-Benz Canada Inc. are Daimler companies.

Not to be reprinted, translated or otherwise reproduced, in whole or in part, without written permission.

Printed in the USA.

Thank you for choosing the new Sprinter

First familiarize yourself with your Sound 5. Read these Operating Instructions, particularly the safety and warning notes before driving. You will then be able to enjoy your Sound 5 even more and avoid endangering yourself and others.

The equipment and functions of your Sound 5 may differ depending on your:

- model
- order
- country specification

We are constantly updating our systems to the state of the art.

We therefore reserve the right to make modifications in the following areas:

- Design
- Equipment
- Technology

Therefore, you cannot base any claims on the illustrations or descriptions in these Operating Instructions.

Please consult an authorized Sprinter Dealer if you have any questions.

The Operator's Manual and all supplements are an integral part of the vehicle. You should always keep them in the vehicle and pass them on to the new owner if you sell the vehicle.

We wish you safe and pleasant motoring.

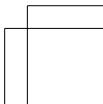
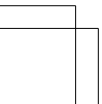
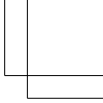
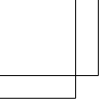

Index	4	At a glance	9	
Introduction	7	Audio	17	

A

Adjusting	
Mid-range	14
Album name	
Display	25
AM waveband	
Setting	18
Audible fast forward/fast rewind	
CD	23

B

Balance	
Setting	13
Bass	
Setting	13

C

Canceling	
Scan mode (CD)	24
CD	
Controls	10
Copy protection	21
Data medium	21
Ejecting	22
General information	20, 21
Multisession	20
Notes on handling	20
Playback options	24
Playing back	22
Random function	24
Repeat	25
Scan mode	23
Skip	23
CD mode	
Displaying playback time	25
Switching to	22
Changing folder	24
MP3/WMA	24
Confirmation tone (BEEP)	
Adjusting the volume	14
Controls	10
CD	10
Radio	10
Copy protection	
CD	21

D

Data medium	
MP3	20
Display	
Album name	25, 26
Playback time	25
Total playback time	25
Displaying	
Track	26

E

Ending	
Repeat (CD)	25
Scan mode (CD)	24
Scan mode (radio)	19

F

Fader	
Setting	13
Fast forward/fast rewind	
CD	23
FM waveband	
Setting	18

G

General information	
CD	20

I

ID3 tag	
see Track	

L

Linear	14
Loading a CD	22
LW (long wave)	
see AM waveband	

M

Manual mute	
Switching off	12
Switching on	12
Metadata	
see Track	

- Mid-range**
 - Adjusting 14
 - MP3**
 - Copyright 21
 - Data medium 20
 - File systems 20
 - Notes 20
 - Playback options 24
 - MP3/WMA**
 - Changing folder 24
 - Multifunction display** 15
 - Multifunction steering wheel** 14
 - Audio 26
 - Selecting a track 26
 - Setting a station 26
 - Multisession CDs** 20
 - MW (medium wave)**
 - see AM waveband
- P**
- Playback options** 24
- R**
- Radio**
 - Controls 10
 - Scan mode 19
 - Radio mode**
 - Switching to 18
 - Random function**
 - CD 24
 - Random playback**
 - see Random function
 - Random playback (CD)**
 - Switching off 24
 - Switching on 24
 - Reception problems** 7
 - Reception quality** 20
 - Repeat** 25
 - CD 25
 - Repeat (CD)**
 - Switching off 25
 - Switching on 25
 - Repeat album** 25
- S**
- Safety notes**
 - Operating safety 7
 - Saving**
 - Stations 19
 - Scan mode**
 - CD 23
 - Radio 19
 - Setting**
 - AM waveband 18
 - Balance 13
 - Bass 13
 - Fader 13
 - FM waveband 18
 - Sound 13
 - Stations 18
 - Treble 13
 - Volume 12
 - Volume boost for traffic
 - announcements 12
 - Waveband 18
 - Skip**
 - CD 23
 - Sound**
 - Adjusting on the radio 13
 - Speed-dependent volume control** 12
 - Starting**
 - Scan mode (CD) 23
 - Scan mode (radio) 19
 - Station**
 - Storing 19
 - Stations**
 - Saving manually 19
 - Manually
 - 18, 19
 - Using automatic search
 - 18, 19
 - Saving using Autostore 19
 - Manually
 - 18, 19
 - Using automatic search
 - 18, 19

Selecting	18
Manually	18, 19
Using automatic search	18, 19
Setting	18, 19
Manually	18, 19
Using automatic search	18, 19
Tuning in	19
Manually	18, 19
Using automatic search	18, 19
Stereo	
Symbol	20
SW (short wave)	
see AM waveband	
Switching off	12
Manual mute	12
Random playback (CD)	24
Repeat (CD)	25
Switching on	11
Manual mute	12
Random playback (CD)	24
Repeat (CD)	25
Switching to	
CD mode	22
Radio mode	18
Symbol	
Stereo	20

T

Total playback time	
Display	25
Track	
Displaying	26
Traffic announcements	
Volume boost	12
Treble	
Setting	13

V

VHF

 see FM waveband

Volume

Adjusting	12
Confirmation tone (BEEP)	14

Volume boost

Traffic announcements	12
-----------------------------	----

W

Waveband

Setting	18
---------------	----

Operating safety

General notes

WARNING

Your attention must always be focused on the traffic conditions. Only operate the audio device if traffic conditions permit you to do so. Bear in mind that, at a speed of only 50 km/h, your vehicle covers a distance of nearly 14 m per second.

This device complies with Part 15 of the FCC Rules. Operation is subject to the following two conditions:

1. This device may not cause harmful interference, and
2. this device must accept any interference received, including interference that may cause undesired operation.

WARNING

Change or modification not expressly approved by the party responsible for compliance could void the user's authority to operate this equipment.

- !** Note: This equipment has been tested and found to comply with the limits for a Class A digital device, pursuant to Part 15 of the FCC Rules. These limits are designed to provide reasonable protection against harmful interference when the equipment is operated in a commercial environment. This equipment generates, uses and can radiate radio frequency energy and, if not installed and used in accordance with the instruction manual, may cause harmful interference to radio communications.

WARNING

This equipment complies with FCC radiation exposure limits set forth for uncontrolled equipment and meets the FCC radio frequency (RF) Exposure Guidelines in Supplement C to OET65.

This equipment has very low levels of RF energy that is deemed to comply without

maximum permissive exposure evaluation (MPE). But it is desirable that it should be installed and operated with at least 8 inches (20 cm) and more between the radiator and a person's body (excluding extremities: hands, wrists, feet and legs.)

- !** Electronic devices that you bring into the vehicle yourself can cause significant problems with the radio reception.

Correct use

Always observe the following when using the audio device:

- the safety notes in this manual
- national road traffic regulations

- i** If work on electronic equipment and its software is carried out incorrectly, this equipment could stop functioning. Even systems that have not been modified could be affected because the electronic systems are connected. Electronic malfunctions can seriously jeopardize the operational safety of your vehicle.

WARNING

Modifications performed on electronic components or software can cause malfunctions. The radio, amplifier, CD drive and telephone are linked together.

If one of the components is inoperative or was not properly removed or replaced, the function of the other components may be impaired.

This could considerably compromise the operating safety of your vehicle.

We therefore recommend always having service work on electronic components performed at an authorized Sprinter Dealer.

Equipment on your audio device

i These Operating Instructions describe all the standard and optional equipment of your audio device, as available at the time of going to print. Country specific differences are possible.

Please note that your audio device may not be equipped with all the features described.

This also includes safety relevant systems and functions. Therefore, the equipment on your audio device may differ from that in the descriptions and illustrations.

If you have questions about equipment and operation, consult any authorized Sprinter Dealer.

Qualified specialist workshops

i Read the information on qualified specialist workshops in the vehicle Operator's Manual.

Overview of controls	10
Operation	11
Basic functions	11
Multifunction steering wheel	14
Multifunction display	15

Overview of controls

Overview

At a glance

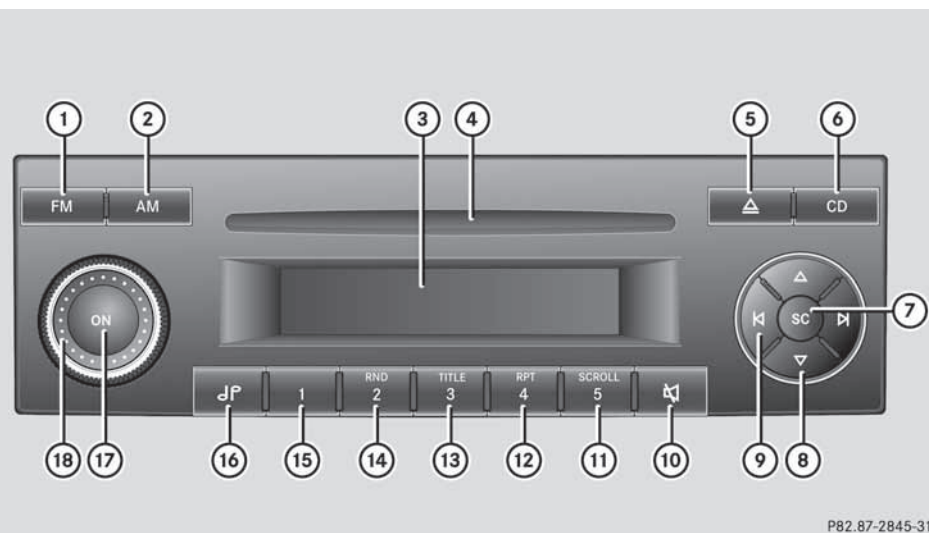

P82.87-2845-31

	Function	Page
①	Pressing briefly: switches to FM Pressing and holding: switches on/off RDS	
②	Switches between the AM and WB (weather band) waveband	
③	Display	
④	Disc slot	
⑤	CD eject button	
⑥	Switches to CD or AUX mode	
⑦	Radio mode Starts scan mode CD mode Starts scan mode	

	Function	Page
⑧	Radio mode Manual station tuning MP3 mode Changes folder	
⑨	Radio mode Starts station search CD mode Skips tracks Fast forward/rewind	
⑩	Pressing briefly: mutes Pressing and holding: switches RDS on/off	
⑪	Radio mode Station preset 5 CD mode Stops display	

	Function	Page
⑫	Radio mode Station preset 4 CD mode Repeats track	
⑬	Radio mode Station preset 3 CD mode Displays playback time MP3 mode Displays album/track name/playback time	
⑭	Radio mode Station preset 2 CD mode Random playback	

Function overview

Using Sound 5 you can operate the following functions:

- radio with FM, AM (medium wave), WB (weather band), short wave and long wave
- CD audio playback
- MP3 playback of CD

Operation

General notes

The system can be operated:

- using the controls on Sound 5
- using the multifunction steering wheel

You can also operate many of the Sound 5 functions using the multifunction steering wheel (▷ page 14). The respective Sound 5 functions, e.g. the selected radio station or CD track, are then shown in the multifunction display. A requirement for this is that you have selected the corresponding menu in the multifunction display (▷ page 15).

The audio device emits an acoustic confirmation tone. When you press and hold

	Function	Page
⑮	Radio mode Station preset 1	
⑯	Calls up the sound menu Volume boost Regional mode	
⑰	Switches on/off	
⑱	Adjusts the volume	

a button for an operation (e.g. storing a station), there is a tone at the end.

Basic functions

Switching on/off

Switching on

- ▶ Turn key to position 1 or 2 in the ignition lock

or

- ▶ Press the **ON** button.

In both cases the audio device resets the operating mode set before it was turned off.

- i** If the key is not inserted in position 1 or 2 in the ignition lock, the audio device switches itself off again automatically after around 60 minutes.

Switching off

- ▶ Turn key to position 0 in the ignition lock and remove it
- or
- ▶ Press the  button.

Switching the sound on/off (mute)

Switching on manual mute

- ▶ Briefly press the  button.





P82.86-9220-31

The audio device switches to mute. In CD mode, the CD stops.

- i** If an RDS station has been set and mute is activated, **TP-INFO** is still shown in the display.
- i** Instead of the standard mute, you can also activate traffic announcement mute. In this case, you will only hear traffic announcements. The remaining program is muted.



Switching off manual mute

- ▶ Briefly press the  button.
- or
- ▶ Turn the  control.
You will hear the audio source you were listening to before mute was activated.

Adjusting the volume

- i** A separate volume setting applies for CD, AUX and telephone operating modes. When you set the volume, the audio device saves the setting automatically for whichever operating mode is currently active.

Adjusting the volume

- ▶ Turn the  control on Sound 5
- or
- ▶ Press the  or  button on the multifunction steering wheel.
The audio device saves the volume settings when it is switched off.

- i** If the volume is above the maximum volume when switched off, it may be quieter when switched on again if the vehicle is at a standstill for a longer period.

Speed-dependent volume control

The audio device can control the volume according to the speed of the vehicle.

Boosting volume for traffic announcements

You can set a volume boost for traffic announcements.

- ▶ Press the  button repeatedly until the menu for setting the volume boost appears. The current setting will appear.







P82.86-9185-31

- i** Setting 0: no increase
Setting 3: maximum increase
- ▶ Turn the  control.
The setting will change.
The new setting is saved as soon as the setting menu disappears.

Sound settings

Adjusting the sound settings

- ▶ Press the  button.
 - ▶ Turn the  control on Sound 5.
- or
- ▶ Press the  or  button on the multifunction steering wheel.
The display in the instrument cluster shows the current setting.

Balance and fader



Common balance and fader settings apply for the radio, CD, AUX and telephone operating modes.

Setting the fader (volume distribution between front and rear)

- ▶ Press the  button repeatedly until the fader menu appears.
The current setting will appear.



P82.86-9190-31



- ▶ Turn the  control.
- or
- ▶ Press the  or  button on the multifunction steering wheel.
The setting will change.
The new setting is saved as soon as the fader menu disappears.

Setting the balance (volume distribution between left and right)

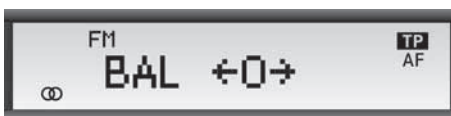
- ▶ Press the  button repeatedly until the balance menu appears.
The current setting will appear.



P82.86-9192-31

- ▶ Turn the  control.
- or
- ▶ Press the  or  button on the multifunction steering wheel.
The setting will change.
The new setting is saved as soon as the balance menu disappears.

Bass, treble and mid-range

- i** Different bass/treble settings are possible for all operating modes except telephone mode*.



When you set the bass or treble, the audio device saves the setting automatically for whichever operating mode is currently active.

Setting the bass

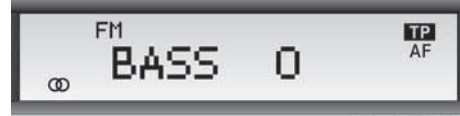
- ▶ Press the  button repeatedly until the bass menu appears.
The current setting will appear.



P82.86-9191-31



- ▶ Turn the  control.
- or
- ▶ Press the  or  button on the multifunction steering wheel.
The setting will change.
The setting is saved as soon as the bass menu disappears.

Setting the treble

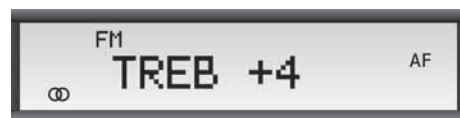
- ▶ Press the  button repeatedly until the treble menu appears.
The current setting will appear.



P82.86-9184-31



- ▶ Turn the  control.
- or
- ▶ Press the  or  button on the multifunction steering wheel.
The setting will change.
The new setting is saved as soon as the treble menu disappears.

Adjusting the mid-range

- ▶ Press the  button repeatedly until the **MIDDLE** mid-range menu appears.
The current setting will appear.



P82.87-2849-31

- ▶ Turn the  control.
- or
- ▶ Press the  or  button on the multifunction steering wheel.
The setting will change.
The new setting is saved as soon as the mid-range menu disappears.

Linear

This function adjusts the following settings to medium:

- Volume
- Fader
- Balance
- Bass, treble and mid-range
- Volume of the traffic announcements (TA)
- Volume of the confirmation tone (BEEP)
- ▶ Press and hold the  button until you hear a tone.

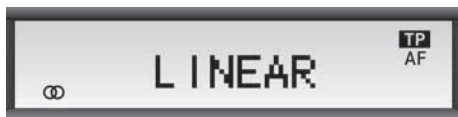

P82.86-9188-31



The settings are reset to medium.

Adjusting the volume of the confirmation tone

- ▶ Press the  button repeatedly until the **BEEP** menu appears.
The current setting will appear.



P82.87-2850-31

- ▶ Turn the  control.
- or
- ▶ Press the  or  button on the multifunction steering wheel.
- ▶ The setting will change.
The new setting is saved as soon as the menu disappears.

Multifunction steering wheel

WARNING

A driver's attention to the road and traffic conditions must always be his/her primary focus when driving.

For your safety and the safety of others, selecting features through the multifunction steering wheel should only be done by the driver when traffic and road conditions permit it to be done safely.

Bear in mind that at a speed of just 30 mph (approximately 50 km/h), your vehicle is covering a distance of 44 feet (approximately 14 m) every second.

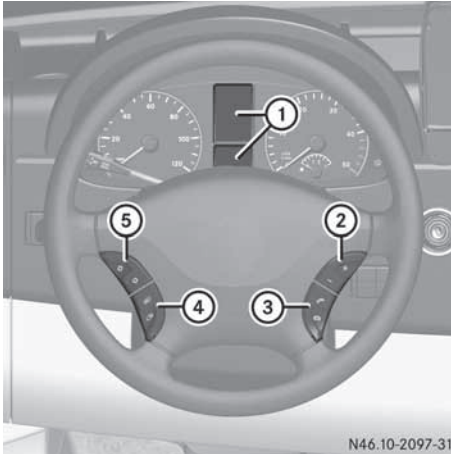

N46.10-2097-31

	Function	Page
①	Multifunction display	15
②	Increases the volume	12
	Reduces the volume	12
③	Accepts a call Rejects or ends a call	
④	Selects a menu Scrolls up Scrolls down (see the vehicle Operator's Manual)	
⑤	Selects a submenu or list entry: Scrolls up Scrolls down (see the vehicle Operator's Manual)	

i The telephone function is not supported by vehicles with Sound 5.

Multifunction display

General notes

The text field in the multifunction display shows values, settings and display messages. In order to operate the audio function using the multifunction steering wheel, the instrument cluster in the multifunction display must be switched to the respective function.

Switching the multifunction display

► On the multifunction steering wheel, press the or button repeatedly until the desired menu appears.

The following displays are shown as examples.

Radio mode display

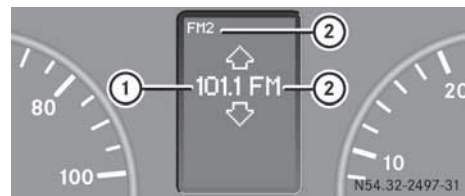

N54.32-2497-31

- ① Station name (if transmitted) or frequency
- ② Waveband with memory position number (if transmitted)

CD mode display



N54.32-2498-31

- ① Current CD
- ② Current track

Audio equipment features	18
Radio mode	18
Audio CD and MP3 mode	20
Audio operation using the multi- function steering wheel	26

Audio equipment features

i These Operating Instructions describe all the standard and optional equipment of your audio device, as available at the time of going to print. Country specific differences are possible.

Please note that your vehicle may not be equipped with all the functions described here.

Radio mode

Switching to radio mode

You can use the **FM** and **AM** buttons to call up the following wavebands:

- FM: station memory 1–5
- FM: station memory 6–10
- FM-AS: Autostore
- AM: MW (medium wave)
- AM: LW (long wave)
- AM: SW (short wave)
- AM: WB (weather band)

The station last selected on the chosen waveband is displayed.

i LW and SW wavebands are not available on all units (depends on sales area).

Switching wavebands

Setting the FM waveband

i FM waveband:

- FM (VHF)
87.5–108 Mhz

▶ Press the **FM** button repeatedly until one of the FM wavebands appears (FM 1–5, FM 6–10 or FM-AS).



P82.86-9197-31

The audio device selects the last station you were listening to that was set on one of the three FM wavebands.

Setting the AM waveband

i AM wavebands:

- MW (medium wave):
531–1620 kHz
- LW (long wave):
153–282 kHz
- SW (short wave):
5800–6250 kHz

Frequency steps specified are only valid for Europe. Other frequency ranges may be used in other areas.

▶ Press the **AM** button repeatedly until one of the AM wavebands appears.

The audio device selects the last station you were listening to.

Selecting a station

Stations may be set in the following ways:

- Selecting using station search
- Selecting using manual search
- Selecting using memory presets

Selecting using station search

▶ Set the desired waveband (> page 18).

▶ Press the  button.

Ascending search of frequencies starts.

or





▶ Press the  button.

Descending search of frequencies starts.

In both cases the search stops at the next station which can be received.





i When traffic announcements are enabled, the station search only stops at stations with a strong reception signal and an RDS signal. If traffic announcements are switched off, the station search also stops at stations without an RDS signal.

Selecting using manual search

- ▶ **i** This function is not available for the weather band (WB).
- ▶ Set the desired waveband (▷ page 18).
- ▶ Briefly press the  or  button on the radio.
The waveband is searched in the frequency steps stated above.
- ▶ Press and hold the  or  button on the radio.
The search does not stop at the frequency steps stated above.

Setting using memory presets

Five stations can be stored as memory presets on each waveband. For the FM wavebands, a total of ten fixed stations and five Autostore memory presets can be used.

- ▶ Set the desired waveband (▷ page 18).
 - ▶ Press a button from  to .
 - ▶ The audio device sets the stored station.
- i** With the FM 6–10, memory presets 6–10 are also set using buttons  to . Memory preset location 10 appears on the display as **FM0**.

Scan mode

- Scan mode plays each station which can be received for around 8 seconds.
- After it has run through the stations twice, the scan stops automatically at the station you were listening to before the scan was started.

Starting scan mode

- ▶ Switch to the desired waveband (▷ page 18).
- ▶ Press the **SC** button.
The station search starts

Ending scan

- ▶ Press the **SC** button again.
The station search stops



Storing stations

Stations can be saved in the following ways:

- Manually
- Using Autostore

Storing manually

Five memory presets are available for each waveband.

- ▶ Set the station to be saved (▷ page 18).
- ▶ Press and hold a button between  and  until you hear a tone.
The station will be saved at the button you have pressed.

Storing using Autostore

- ▶ **i** Saving using Autostore is only possible in the FM-AS waveband.

The audio device fills the five memory presets in the FM-AS waveband with stations in order of reception quality.

If no stations are available, the audio device fills all Autostore memory presets with the lowest frequency.

- ▶ Press the **FM** button repeatedly until the FM-AS waveband appears.

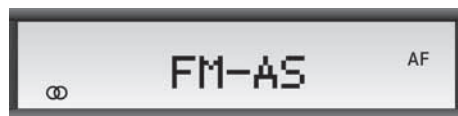

P82.86-9189-31

- ▶ Press and hold the **SC** button until you hear a tone and the Autostore station search starts.



When **AS Seek** disappears, saving is complete.

Reception quality



If a radio station is broadcast in stereo and the reception quality is sufficient, stereo symbol ① appears in the bottom left of the display.

Audio CD and MP3 mode

Important safety notes

WARNING

The CD drive is a class 1 laser product. There is a risk of damage to the eyes due to exposure to invisible laser radiation if you open the casing, or if the casing is faulty or damaged.

You must not open the casing. The unit contains no parts on which you can carry out maintenance. For safety reasons, all maintenance work must be carried out by qualified aftersales technicians.

Notes on handling discs

- Only hold discs by the edge.
- Handle discs carefully to prevent playback problems.
- Avoid getting scratches, fingerprints and dust on discs.
- Clean discs from time to time with a commercially available cleaning cloth.

When cleaning CDs, you should wipe in straight lines from the center outwards rather than in a circular motion.

- When labeling discs, only use a pen designed for that purpose.
- Place discs back in their cases after use.
- Protect discs from heat and direct sunlight.

General notes

Permissible discs

- CD-R and CD-RW

Permissible file systems

- ISO 9660/Joliet standard for CDs

Multisession CDs

For multisession CDs, the content of the first session determines how the audio device will process the CD.

If the first session contains data in audio CD format, for example, and the second session contains MP3 tracks, the audio device will treat the CD as a conventional audio CD. This means that it is not possible to access the MP3 tracks.

If the first session contains MP3 tracks, for example, and the second session contains data in audio CD format, the audio device will not treat the disc as a conventional audio CD. This means that it is only possible to access the MP3 tracks.

File structure of a data carrier

- When you create an MP3 disc, the MP3 tracks can be organized in folders. A folder can also contain subfolders. A disc can contain a maximum of 255 folders. Each folder can contain a maximum of 255 tracks and 255 subfolders. A disc can contain a maximum of 500 tracks. An MP3 CD may contain no more than eight

directory levels. Files in subsequent levels are ignored.

- When moving between folders and tracks, display and selection of these is linear. Any existing hierarchical or nested folder structure is handled as a linear sequence.

Track and file names

- Display of album and track name is limited to a maximum of 31 characters (depending on which character set is used).
- The file extension for MP3 files must be "mp3" and must be separated from the file name by a full stop. Otherwise, the file type will not be recognized by the device.
- The file extension for WMA files must be "wma" and must be separated from the file name by a full stop. Otherwise, the file type will not be recognized by the device.

Notes on copyright

Music tracks that you create or play back are generally subject to copyright protection in accordance with the applicable international and national regulations.

In many countries, reproductions, even for private use, are not permitted without the prior consent of the copyright holder.

Make sure that you know about the applicable copyright regulations and that you comply with these.

If you own these rights yourself, e.g. for your own compositions and recordings, or if the copyright holder has granted you permission, these restrictions do not apply.

Notes on compact discs

- i** Discs with copy protection are not compatible with the audio CD standard and therefore may not be able to be played by the audio device.

You may encounter playback problems when playing copied discs. There is a wide range of data carriers, disc-writing software and writers available. This variety

means that there is no guarantee that the system will be able to play discs that you have copied yourself.

There may be playback problems if you play CDs that you have copied yourself with a storage capacity of more than 700 MB. CDs of this type do not conform to the currently applicable standards.

- !** Do not affix stickers or labels to the discs. They could peel off and damage the drive. The drive is designed to hold discs which comply with the EN 60908 standard. For this reason, you can only use discs with a maximum thickness of 1.3 mm.

If you insert thicker discs, e.g. those that contain data on both sides (DVD on one side and audio data on the other), they cannot be ejected and can damage the drive.

Do not use discs with a diameter of 8 cm, even with an adapter. Only use round discs with a diameter of 12 cm.

Information regarding MP3 files

- To display the title and album name, you need to add the corresponding data to the MP3 file before burning (ID3 tags).
- We recommend a constant bit rate of at least 160 kbit/sec for the compression of MP3 data. With variable bit rates, the display of the elapsed playback time may differ from the time actually elapsed.

Information regarding WMA files

- To display the title and album name, you need to add the corresponding metadata to the WMA file.
- The file extension for WMA files must be "wma" and must be separated from the file name by a full stop. Otherwise, the file type will not be recognized by the device.
- i** A number of factors influence whether or not a WMA file can be played, including:

- Sampling rate
- Bit rate
- Encoding process
- Software used for the creation of the WMA files
- Burn software
- other settings (e.g. copy protection, Digital Rights Management, advanced audio format settings).

Use only current standard software to generate WMA files. Use a sampling rate of 44.1 kHz as well as bit rates between 16 and 320 kbit/s. Do not use other settings such as lossless coding, surround sound, DRM and copy protection, etc.

Do not use compilations that contain WMA files with other settings as this may render the CD unplayable even if only some files on the CD do not fulfill the required conditions.

Loading a CD

WARNING

Insert discs only when the vehicle is stationary. There is a risk of being distracted from the road and traffic conditions if you insert or eject a disc while the vehicle is in motion.

- i** The system may not be able to play audio CDs with copy protection in some cases.
- ▶ Insert the CD into the CD slot with the printed side upwards.
- i** If you insert the CD into the slot when the unit is switched off, the device will automatically turn itself on.
- ▶ The CD is drawn automatically into the slot and playback of the first track starts.
- i** The length of time required to read the data (**LOADING**) depends on various factors (type of media, number of titles, whether copy protected etc.) and may take longer in some cases.

Display with audio CD:



P82.86-9199-31

Display with MP3/WMA CD:

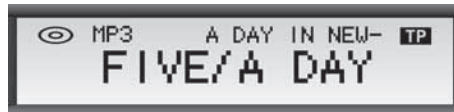

P82.86-9205-31

Initially, the track number is displayed briefly. Then the first ten characters of the track name are shown.

- i** To display the full track name, press the **3** button. The track is only displayed if the corresponding information was added when the CD was created (ID3 tags/metadata). Otherwise, only the file name will be shown.

Ejecting a CD

WARNING

Only eject a disc when the vehicle is stationary. Otherwise, you may be distracted from the traffic conditions and could cause an accident.

- ▶ Press the  button. The CD is ejected.
- ▶ Remove the CD from the disc slot. If the CD is not removed from the slot within 10 seconds, it will be drawn in again for safety reasons.

CD Playback

Switching to CD mode

- ▶ Press the  button once or twice. CD playback begins at the point last listened to when stopped.



P82.86-9199-31

If no CD is inserted, the message **NO CD** appears for a short time.

The device jumps to the last sound source played.

Skipping forwards/back

Operation of this function is identical for audio CDs and MP3/WMA CDs.

- Skip forwards:
The next track is played.
- Skip back:

- **i** Skip back: the current track is restarted if this has been playing for longer than approximately 10 seconds. If it has been playing for less time, the previous track is played.

In CD mode, with an audio CD or MP3/WMA CD inserted:

- ▶ Press the  button to skip forwards.
You will hear the next track.

or

- ▶ Press the  button to skip back.
You hear the previous track or the start of the current track again.

Audible fast forward/fast rewind

In CD mode, with an audio CD or MP3/WMA CD inserted:

- ▶ Press and hold the  button for fast forward.

or

- ▶ Press and hold the  button for fast rewind.

Display with audio CD inserted:

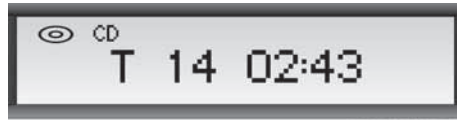

P82.86-9207-31

Display with MP3/WMA CD inserted:

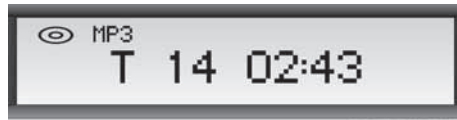

P82.86-9211-31

After the button is released, playback is continued at the current place. The remaining playback time for the current title is displayed for a further 8 seconds.

Scan mode

Scan mode plays each title on the current CD for approximately 10 seconds.

It ends automatically at the track you were listening to before you started the scan. You can also end the scan manually.

Operation of this function is identical for audio CDs and MP3/WMA CDs.

Starting scan mode

In CD mode, with an audio CD or MP3/WMA CD inserted:

- ▶ Press the **SC** button during CD playback.

With audio CD inserted:



P82.86-9212-31

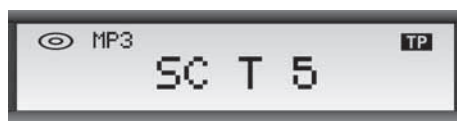

With MP3/WMA CD inserted:



P82.86-9203-31

The title number chosen is displayed.

Ending scan mode

- ▶ Press the **SC** button.
 - ▶ Press the  button.
- or
- ▶ Press the  button.
- The title you are currently listening to remains set.

Changing the folder

- i** This function is only available for MP3/WMA CDs.

In CD mode with MP3/WMA CD inserted

- ▶ Press the  button to skip forwards.
- or
- ▶ Press the  button to skip back.
 - ▶ The next/previous folder is selected.

Each time the folder is changed, the first ten letters of the folder name appear on the display for a short time:



P82.86-9205-31

- i** To display the entire folder name, press the  button.

Once selection of a folder is complete, the display switches back to the track name.

- i** If a folder contains no WMA or MP3 titles, that folder is not displayed.

When moving between folders and tracks, display and selection of these is linear. Any existing hierarchical or nested folder structure is handled as a linear sequence.

The ROOT folder¹ is displayed as **\ROOT** if it contains MP3 or WMA files.

Playback options**Random function (random playback)**

You hear the tracks on the current CD in a random order (e.g. 3, 8, 5, etc.). If you change the CD, random playback ends.

Switching on random playback

In CD mode, with an audio CD or MP3/WMA CD inserted:

- ▶ Press the  button.
- RANDOM** appears for a short time and the display then changes.

With audio CD inserted:

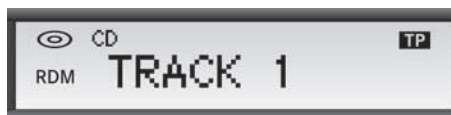

P82.86-9201-31

With MP3/WMA CD inserted:



P82.86-9217-31

Random playback of all albums

This function is only available for MP3/WMA CDs. The tracks of all albums are played in random order.

- ▶ Press the  button twice.
- RANDOM** appears for a short time and the display then changes.



P82.86-9216-31

Switching off random playback

- ▶ Press the  button again.

¹ The topmost directory level of the CD which is set up by the burn software automatically when burning.

Repeat

You hear the current track repeatedly until you switch off the function, change the CD or change the audio source.

Switching on repeat

In CD mode, with an audio CD or MP3/WMA CD inserted:

- ▶ Press the **4** button.
REPEAT appears for a short time and the display then changes.

With audio CD inserted:



P82.86-9199-31

With MP3/WMA CD inserted:



P82.86-9210-31

Switching off repeat

- ▶ Press the **4** button again.

Repeat album

This function is only available for MP3/WMA CDs.

You hear the current album repeatedly until you switch off the function, change the CD or change the album.

Switching on album repeat

With MP3/WMA CD inserted:

- ▶ Press the **4** button twice.
REPEAT appears for a short time and the display then changes.



P82.86-9215-31

Switching off album repeat

- ▶ Press the **4** button again.

Displaying playback time

With audio CD inserted:

- ▶ Press the **3** button.

With audio CD inserted:

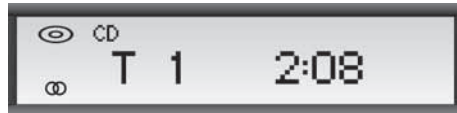

P82.86-9198-31

- i** If you press the **3** button with an MP3/WMA CD inserted, the album and track name are shown, provided that this information was added when the CD was created (ID3 tags/metadata).

Displaying the number of CD titles and total playback time

With audio CD inserted:

- ▶ Press the **3** button twice.

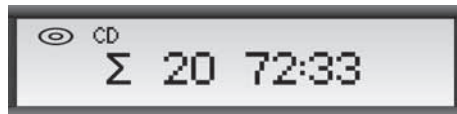

P82.86-9208-31

Displaying album and track name

With MP3/WMA CD inserted:

- ▶ Press the **3** button.







Displaying the album and track name (ID3 tags/metadata)

With MP3/WMA CD inserted:

- ▶ Press the **3** button repeatedly. The album and track name scroll across the display from right to left. If the album and track name are not present as ID3 tags, the file name is shown.
- ▶ **To cancel the display:** press the **5** button.

Audio operation using the multifunction steering wheel





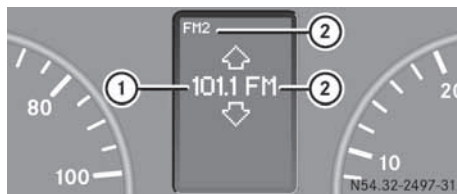

Selecting a radio station

- i** You can change between station selection via memory presets and station selection via frequency in the multifunction display. For information on how to do this, see the vehicle Operator's Manual.
- ▶ Switch the audio device to radio mode.
- ▶ Using the  or  button on the multifunction steering wheel, select the audio display.
- ▶ Press the  or  button briefly on the multifunction steering wheel. Depending on the multifunction display setting, the search stops at the next station which can be received, either stored as a preset or within the frequency range.



- ① Station (if transmitted) or frequency
- ② Waveband with preset number (if transmitted)

Selecting a track

- ▶ Switch the audio device to audio CD or MP3 mode.
- ▶ Using the  or  button on the multifunction steering wheel, select the audio display.
- ▶ Press the  or  button on the multifunction steering wheel. You will hear the next/previous track. Skipping backwards skips to the beginning of the current track if the track has been playing for more than 8 seconds. If the track has been playing for less than eight seconds, it skips to the start of the previous track.
- ▶ **To fast forward/rewind:** press and hold the  or  button on the multifunction steering wheel until the desired position has been reached.



Example display: audio CD mode

- ① Current disc
- ② Current track

